

DANIELS FOOD EQUIPMENT

DVTS-50 TUMBLER

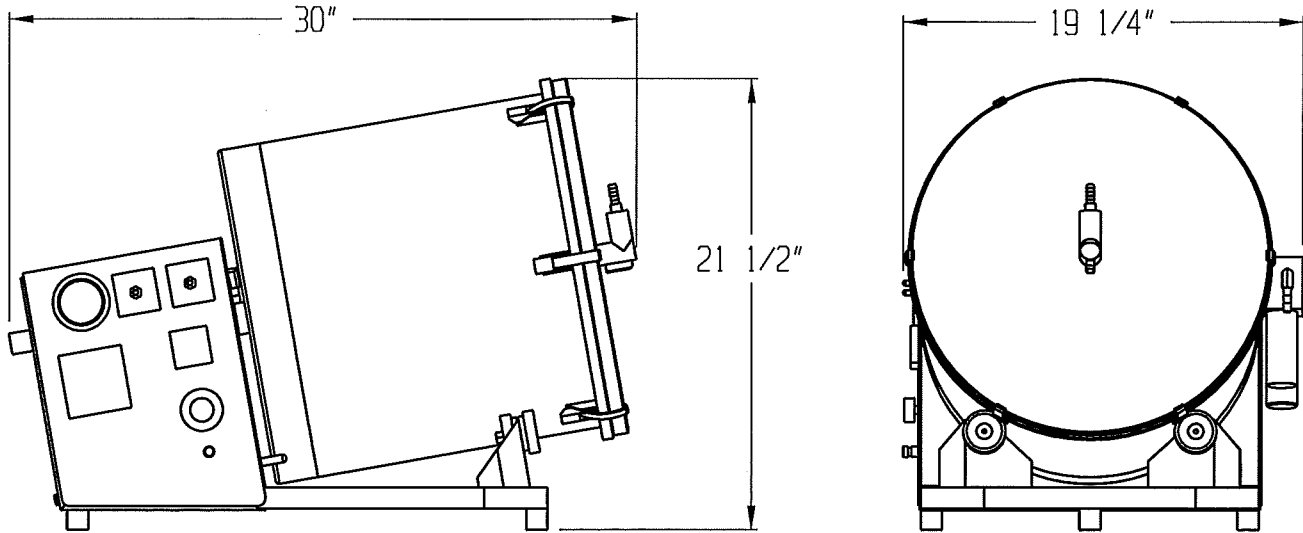

SPECIFICATIONS

TOTAL POWER INPUT:	STANDARD: 15 AMP, 120 VOLT, 60 HZ, 1 PHASE OPTIONAL: 15 AMP, 220 VOLT, 50/60 HZ, 1 PHASE
TUMBLER DRIVE:	DC, ELECTRONIC SPEED CONTROL 0-18 RPM, 1 AMP
VACUUM PUMP:	STANDARD: 1/8 HP, 25 IN HG MAX, 3.6 AMP OPTIONAL: 1/8 HP, 25 IN HG MAX, 1.5/1.8 AMP
TIMER:	ELECTRONIC, HOURS/MINUTES
ELECTRONIC CONTROLS:	TUMBLER SPEED-ADJUSTABLE, TUMBLER “START” TIMER VACUUM PUMP “STOP”-“START” TOGGLE
MAXIMUM CAPACITY:	50-LBS.
WEIGHT:	83-LBS. (NET)

DANIELS FOOD EQUIPMENT

310 NORTH CLAYBORN AVE. PARKERS PRAIRIE, MN. 56361 PHONE: (218) 338-5000 FAX (218) 338-5909.
WEB: www.danielsfood.com E-MAIL: danielsfood@midwestinfo.net