

Value-Driven Automation

Enhance Productivity and Quality



Quality

The 870's fully automatic weighing, wrapping and labeling capabilities ensure optimal package presentation. From high-resolution printed labels to strong, tightly wrapping seals, retailers and their customers benefit from the packaging capabilities of the 870.



Easy to Use

Spend less time training operators with the 870's intuitive user interface. With trouble-shooting prompts and step-by-step graphical guidance, operation takes no time to master.



Fast Production

With its ability automatically to weigh, wrap and label items with speeds up to 28 packs-per-minute, the 870 Auto Wrapper maximizes throughput. The machine offers high-speed label printing at 6 inches-per-second. Less time spent in the backroom wrapping packages enables more time assisting customers.



Small Footprint

With a total footprint of only 19 ft², the 870 Auto Wrapper has one of the smallest footprints of any fully automated wrappers on the market. Film and labels can be easily accessed from the front, requiring less space overall.



870 Auto Wrapper

Automatic Weigh, Wrap and Label

Packaging quality matters to you and your customers. The 870 Auto Wrapper provides excellent fully automatic weighing, wrapping and labeling for maximum efficiency. The 870's small footprint and ergonomic design makes it a great choice for compact backroom spaces.

- Fully automatic weigh, wrap, and label processes
- Wrapping speed of 28 trays-per-minute
- High-speed label printing of 6 inches-per-second
- Intuitive user interface with touchscreen and tactile keyboard
- Easy to clean, hygienic design
- Quick and easy film and label changing
- Small footprint of 19 ft²

The Ideal Choice for Value

The high-performance 870 Auto Wrapper is perfect for retailers that demand excellent and efficient weighing, wrapping and labeling processes. Robust, intuitive and efficient, 800 Series wrapping machines support weighing, wrapping and labeling for optimized backroom processes.



Technical data

870 Auto Wrapper

Speed

28 packs-per-minute

Tray Sizes

1S, 2S, 17S, 20S, 4S, 8S, 9, 10S, 16S, 12S, 7, 25S

Film

METTLER TOLEDO Certified Film CF-10
14" width or 20" width

Footprint (ft²)

19 ft²

Configuration

Exit front

Weighing Capacity

0.7 oz.–33 lb.

Weighing Range

0–13 lb./13–33 lb.

Machine Weight

850 lb.

Operating Range

40° F–95° F (5° C–35° C)

PLU Presets

300

Label Sizes

(Auto Application)
1.1"–4.1" length

1.4"–3.1" width

9" label roll capacity

Labeler Options

Single printer, front right

Electrical

208 or 240 VAC, single phase,
50–60Hz, 3 kVA, 15 A

Controller

800 Series Controller
Embedded Linux OS
Compact Flash Memory

Network Interface

Wired Ethernet
Wireless upgrade available

Display/Keyboard

12.1" color LCD touchscreen
Tactile keypad

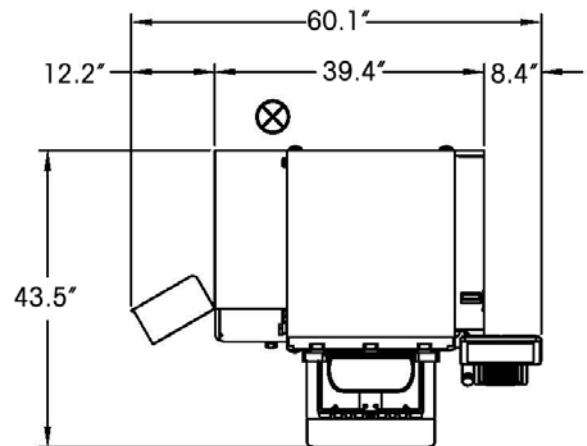

Dimensions in inches



METTLER TOLEDO Group

Retail Division

Local contact: www.mt.com/contacts

Subject to technical modifications

© 01/2020 METTLER TOLEDO. All rights reserved

Document No. 30468554 A

MarCom Industrial

www.mt.com/retail

For more information

