

REVISION HISTORY				
REV	ECN	DATE	DONE BY	DESCRIPTION
0	3433	8/24/2016	EDD	INITIAL RELEASE
1	4009	8/27/2019	PG	REPLACED 1903-311 WITH 1903-860 ADDED 2 MORE 1909-001

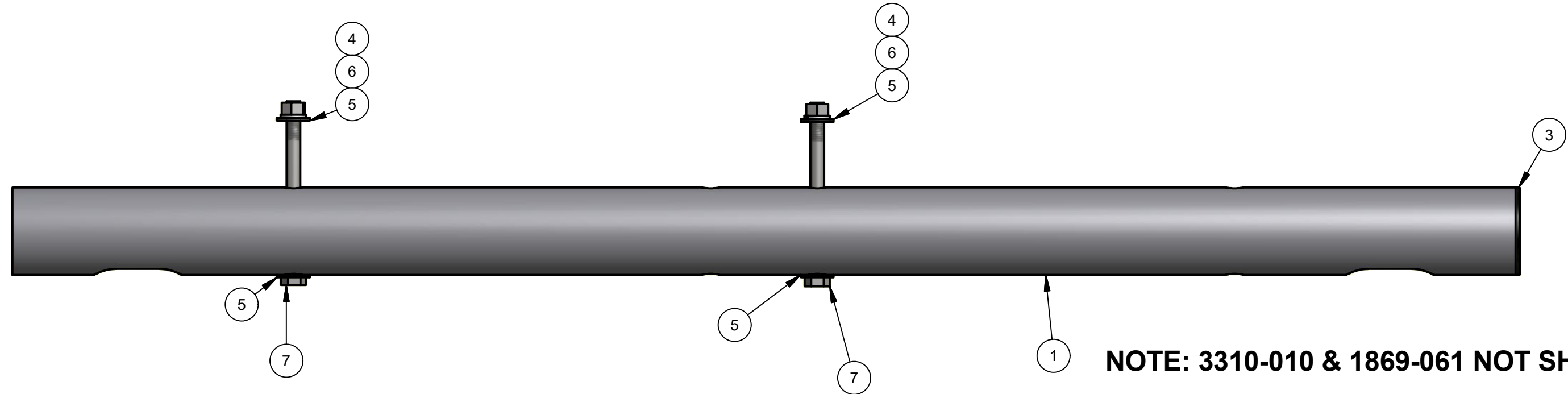

**NOTE: 3310-010 & 1869-061 NOT SHOWN**

8	3	1869-061	GROMMET, RUBBER, 1 3/4 HOLE
7	2	1903-860	SCR, CAP, HEX HEAD SS 5/16-18 4" L PARTIAL THD
6	2	1907-006	LOCKWASHER, SPLIT, SS, 5/16 MED
5	4	1909-001	WASHER, FLAT, SS, 5/16
4	2	1911-014	NUT, HEX, FINISH, SS, 5/16-18
3	1	1970-016	PLUG, HOLE, ROUND 2", PLASTIC, BLACK
2	1	3310-010	BAG, POLYETHYLENE, PLAIN, 7X8
1	1	6137-152	SUPPORT POST TUBE, 2" OD, ES SCALEMATE, DIGI
ITEM	QT	PART NUMBER	DESCRIPTION

**Material Specification**

**HEAT SEAL/AMPAK**

CLEVELAND, OHIO 44125

<p><b>CONFIDENTIAL</b> THIS PRINT IS PROPERTY OF, AND DISCLOSES PROPRIETARY INFORMATION OF HEAT SEAL. IT IS LOANED FOR REFERENCE ONLY, AND MAY NOT BE REPRODUCED OR FORWARDED ELECTRONICALLY IN ANY MANNER, OR ITS CONTENTS DISCLOSED TO OTHERS, WITHOUT THE EXPLICIT WRITTEN PERMISSION OF OWNER AND MUST BE DESTROYED UPON REQUEST.</p>	UNLESS OTHERWISE SPECIFIED:	CREATED: 8/23/2016	DESCRIPTION: <b>KIT, 2" POLE, ES SCALEMATE, DIGI</b>	
	ALL DIMENSIONS IN INCHES	CREATED BY: duffe	DRAWING NUMBER: <b>6137-153</b>	
	STANDARD TOLERANCES:	CHECKED:	REVISION: <b>1</b>	
	0.00: ± .010 0.000: ± .005 ANGLE: ± 1'	CHECKED BY:	SIZE: B	SCALE: NONE