



Project _____

Item Number _____

Quantity _____

SL50/SL80/SL120



SL50 / SL80 / SL120 SILVERLINE Spiral Mixers

Models:

- SL50: 70 QUART (68 LITER) SPIRAL MIXER
- SL80: 135 QUART (130 LITER) SPIRAL MIXER
- SL120: 180 QUART (170 LITER) SPIRAL MIXER



Spiral Mixer

Features:

- Stainless steel bowl, spiral dough hook, and shaft
- Powerful dual high torque motors- for bowl and dough hook
- Has two fixed speeds and reverse function
- Dual electronic timers allow automatic shift from 1st to 2nd speed
- Mixer is equipped with built in castors and leveling feet for easy positioning and set-up
- Safety switches to protect operator from injury if bowl lid is open
- Powerful belt drive provides low vibration, low noise, and economical maintenance for years of reliable service
- Heavy-duty reinforced dough hook easily handles large, heavy batches with ease
- Polished finish stainless steel bowl
- Bowl guard allows easy addition of ingredients while mixing

Dough Capacity:

SL50: 110lb (50kg)
 SL80: 176lb (80kg)
 SL120: 265lb (120kg)

Dough hook:

1st speed: 95 rpm
 2nd speed: 190 rpm

Bowl:

20 rpm

Univex Corporation

Standard Accessories:

- Heavy-duty stainless steel bowl
- Stainless steel dough hook

Warranty:

- One year, on-site parts and labor



Univex Corporation
www.Univexcorp.com

3 Old Rockingham Rd
Salem, NH 03079
United States of America

TEL: (800)258-6358
INTL TEL: (603)893-6191
FAX: (800)356-5614
INTL FAX: (603)893-1249



SILVERLINE Spiral Mixer

SL50 / SL80 / SL120

Line drawing is the SL120

	SL50	SL80	SL120
A	22" (55.9cm)	27" (68.58cm)	31" (78.74cm)
B	36" (91.4cm)	45" (114.3cm)	54" (137.16cm)
C	45" (114.3cm)	51" (129.54cm)	57" (144.78cm)

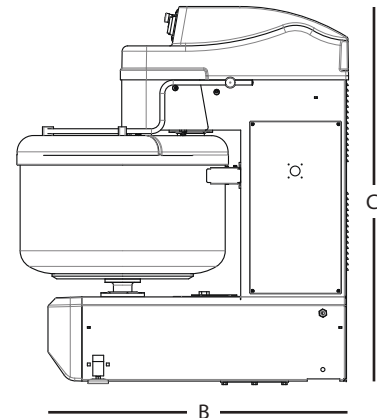
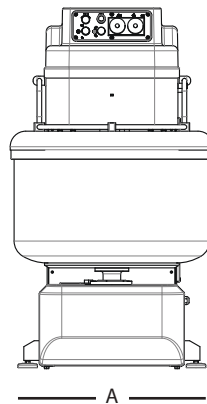
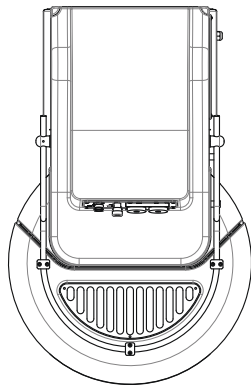

Electrical Information

Model	Voltage	Phase	Spiral hp(kW)	Bowl hp(kW)	Total hp(kW)	Spiral Amps	Bowl Amps	Total Amps
SL50	208-240	3	2.5/3.5 (1.9/2.6)	.75 (.55)	4.25 (3.15)	6.25	1.3	7.5
SL80	208-240	3	3.5/6 (2.6/4.5)	.75 (.55)	6.75 (5.05)	24.6	2.65	27.25
SL120	208-240	3	6/8.3 (4.4/6.1)	1 (.75)	9.3 (6.85)	22	3.68	25.68

NEMA #:

SL50: L15-20-P
 SL80: L16-30-P
 SL120: Hard Wire
 With Shutoff

True 3 phase power is required, Delta or other semi 3 phase power set up 's will not work

Transmission: Heavy duty low noise and low vibration belt drive.

Controls: Control panel with digital timers. Separate timers for high and low speed. Security key for manual use. Bowl reverse direction switch.

Bowl Guard: Swings open for full access to bowl. Guard must be closed for mixer operation.

Shipping Information

Model	Net Weight	Shipping Weight	Overall Dimensions
SL50	474 lbs. (215Kg)	548 lbs. (265Kg)	59" (150cm) H x 31" (78.7cm) W x 32" (82cm) D
SL80	728 lbs. (330Kg)	838 lbs. (380Kg)	67" (170cm) H x 31" (80cm) W x 50" (126cm) D
SL120	1,080 lbs. (490Kg)	1,190 lbs. (540Kg)	67.3" (171cm) H x 33" (83cm) W x 53" (135cm) D

*The weight and dimensions of the pallet are included in the weight and dimensions above.



Univex Corporation
 www.Univexcorp.com

3 Old Rockingham Rd
 Salem, NH 03079
 United States of America

TEL: (800)258-6358
 INTL TEL: (603)893-6191
 FAX: (800)356-5614
 INTL FAX: (603)893-1249