

Project _____

Item Number _____

Quantity _____

SRM12+ Mixer



12 Quart (qt.) Countertop Mixer

MADE IN THE USA

Model:

- SRM12+: 12 qt. COUNTERTOP MIXER (WITH OR WITHOUT PTO HUB)



Countertop Mixer

Features:

- 1/3 hp capacitor start motor
- Variable Speed Drive: 4 fixed speeds or any speed in-between
- Change speeds without having to stop the mixer
- Two-piece, stainless steel, dishwasher safe safety guard
- Heavy-duty stainless steel bowl
- Interlock switches protect operator from injury if safety guard is open or bowl is lowered
- Hardened alloy gears in transmission
- Durable NSF approved hybrid epoxy/polyester powder coat finish

Standard Accessories:

- 12 qt. stainless steel bowl
- Dough hook
- Batter beater
- Wire whip
- Ingredient chute
- Bowl scraper

Optional Accessories:

- 15 minute timer
- Heavy duty SS wire whip
- Sweet dough beater
- 12 qt. pastry knife
- Four wing beater
- Cover

Optional Attachments:

- #12 Power Take Off (PTO) hub
- VS9 vegetable slicer with adjustable knife
- VS9H vegetable shredder with plate holder and 3/16" plate (additional plate size variations, grater plates, and julienne plate available)
- ALMFC12 meat and food grinder

Warranty:

- Two year, on-site parts and labor

Univex Corporation



WE RAISE THE BAR. WE SET THE STANDARD.

12 Quart Countertop Mixer

SRM12+

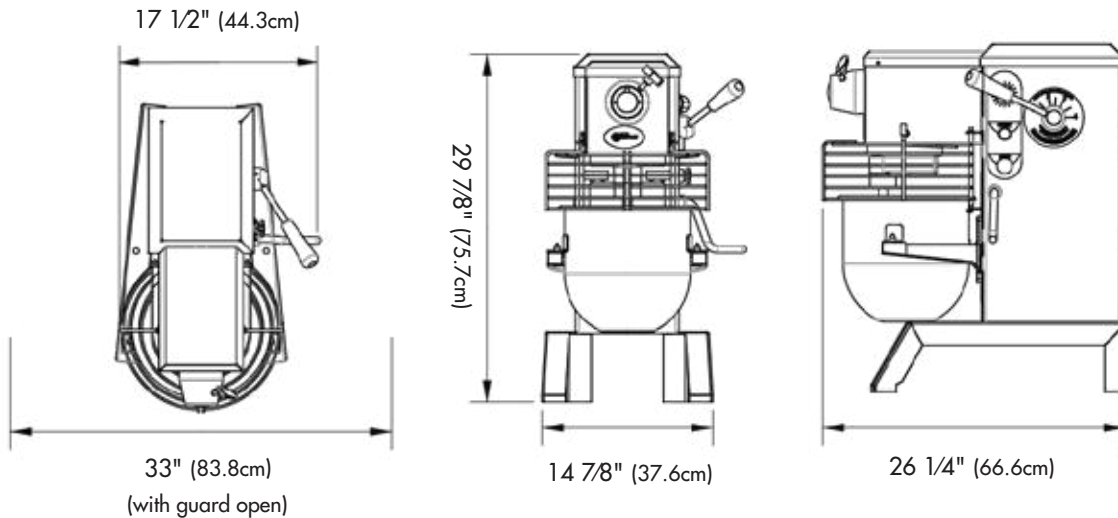

*Shown with optional PTO and timer

Shipping Information		
Net Weight	Shipping Weight	Overall Dimensions
186 lbs. (84.3Kg)	220 lbs. (99.8Kg)	41" (104.1cm) H x 33" (83.8cm) W x 22" (55.9cm)
The weight and dimensions of the pallet are included in the weight and dimensions above.		

Electrical Information (60Hz)				
Attached 6 foot cord				
	Voltage	Phase	AMPS	NEMA
Standard	115	1	6.6	5-15P
Optional	208-240	1	3.8	6-15P

Mixer Speeds				
Speed	1	2	3	4
Beater Shaft (RPM)	152	228	321	406
PTO (RPM)	117	178	231	316

Bowl Capacity: 12 qts. (11.3 liters)

Motor: 1/3 hp capacitor start

Controls: Momentary contact stop & start buttons and contactor

Bowl Lift: Ergonomic hand operated crank, self locking in top and bottom position

Transmission: Featuring hardened alloy gearing and torque sensing variable speed pulleys

Power Take Off (PTO): #12 Hub



Univex Corporation
www.Univexcorp.com

3 Old Rockingham Rd
Salem, NH 03079
United States of America

TEL: (800)258-6358
INTL TEL: (603)893-6191
FAX: (800)356-5614
INTL FAX: (603)893-1249