

# DANIELS FOOD EQUIPMENT

## DMX and DMX QUAD 300HD MIXER

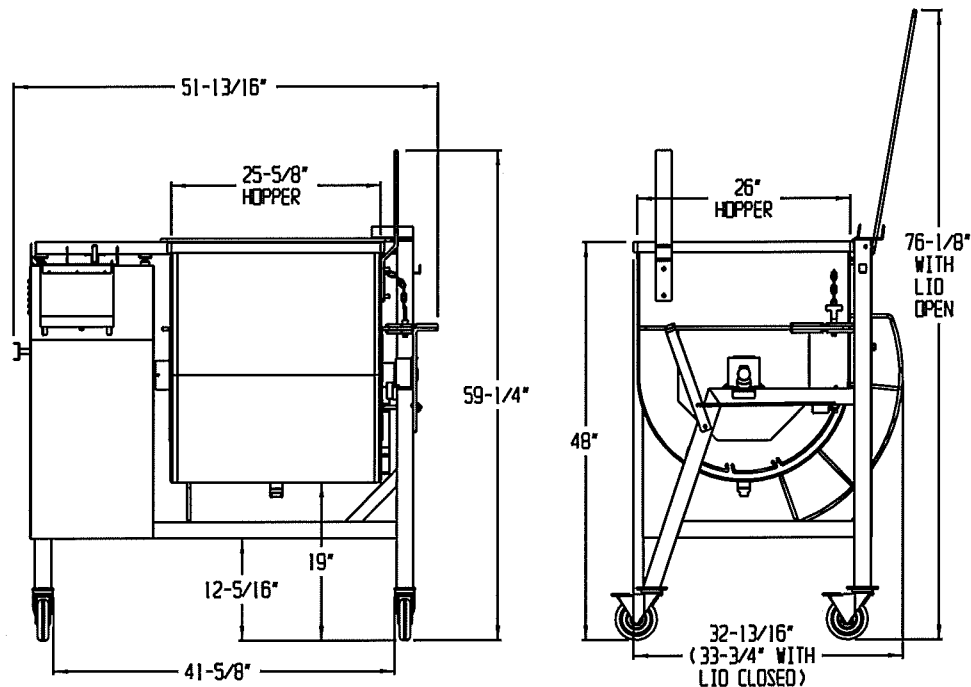

### SPECIFICATIONS

- MOTOR:** STANDARD: 5 HP, 3 PH, 230 V, 60 Hz, 13.4 AMP  
OPTIONAL: 5 HP, 3 PH, 208/460 V, 60 Hz, 14.7/6.7 AMP
- PADDLE RPM:** INNER: 28-3/4 RPM OUTER: 28-3/4 RPM
- TIMER:** LED READOUT – SECONDS / MINUTES
- DIRECTIONAL CONTROL:** FORWARD – STOP – REVERSE
- HOPPER CAPACITY:** 300 LBS
- HOPPER CONSTRUCTION:** 12 GA STAINLESS STEEL, 110° DUMPING, REMOVABLE PADDLE, CLEANOUT DRAIN, TRANSPARENT COVER WITH SAFETY LOCKOUT
- FRAME:** 11 GA STAINLESS STEEL TUBING, OPEN UNDER HOPPER FOR EASY DUMPING, LOCKING SWIVEL CASTERS
- DUMP HEIGHT:** 12-7/8"
- WEIGHT:** 665 LBS

### DANIELS FOOD EQUIPMENT

310 NORTH CLAYBORN AVE. PARKERS PRAIRIE, MN. 56361 PHONE: (218) 338-5000 FAX (218) 338-5909

WEB: [www.danielsfood.com](http://www.danielsfood.com)

E-MAIL: [danielsfood@midwestinfo.net](mailto:danielsfood@midwestinfo.net)

1/16/2020